

Comprimento = 100cm		Largura = 11,8cm	
Classe de carga	Altura (cm)	Peso (kg)	Código
A15	9,5	7,8	00202

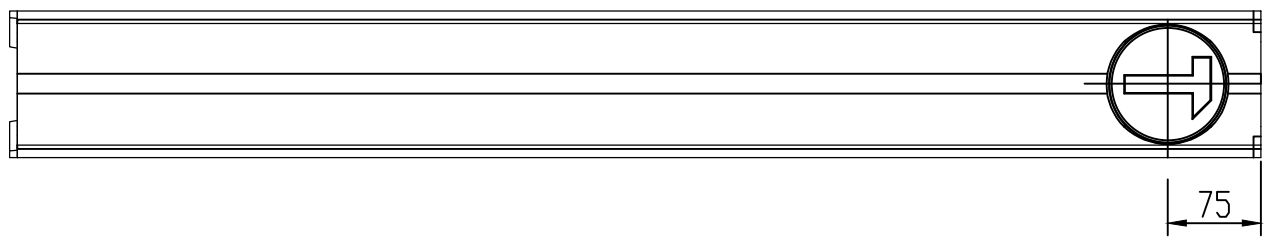
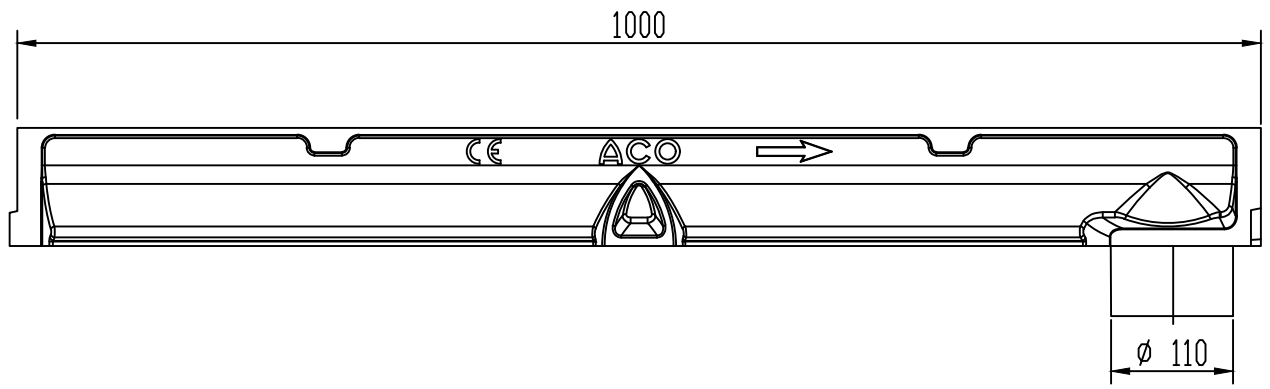
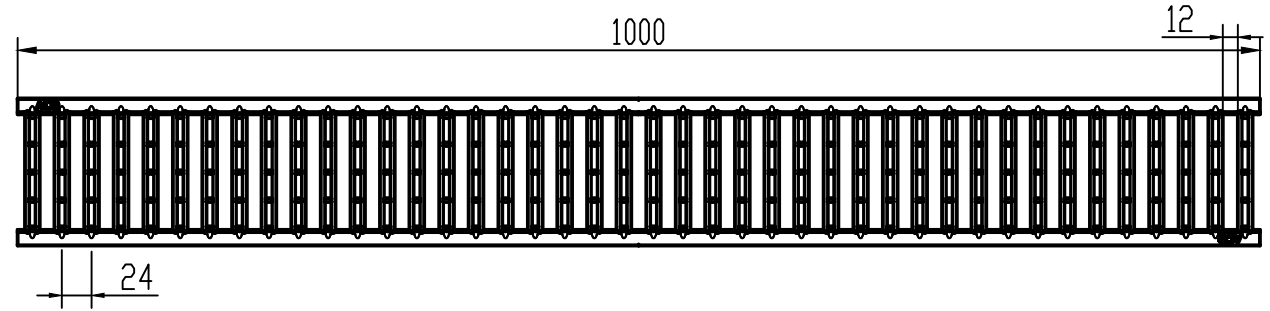
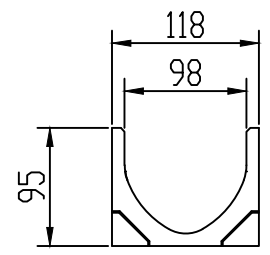
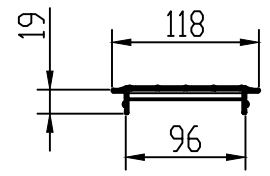

GRELHA PASSARELA AÇO GALVANIZADO - A 15

FUMINAS

www.fuminas.com.br

ESC. 1:5

Description:

PRODUTO CODIGO 00202

Canal de Concreto Polímero - CI A15
Sistema de encaixe macho e fêmea.

	Date	Name
Dwg.		
Comp.		
Norm		

Reference Number:
COD. 00202
ACO SELF
Self100 H9,5 - A15

Measures: mm

FUMINAS

FUPLASTIC