

Comprimento = 100cm		Largura = 20,0cm	
Classe de carga	Altura (cm)	Peso (kg)	Código
A15	15,0	18,1	00224

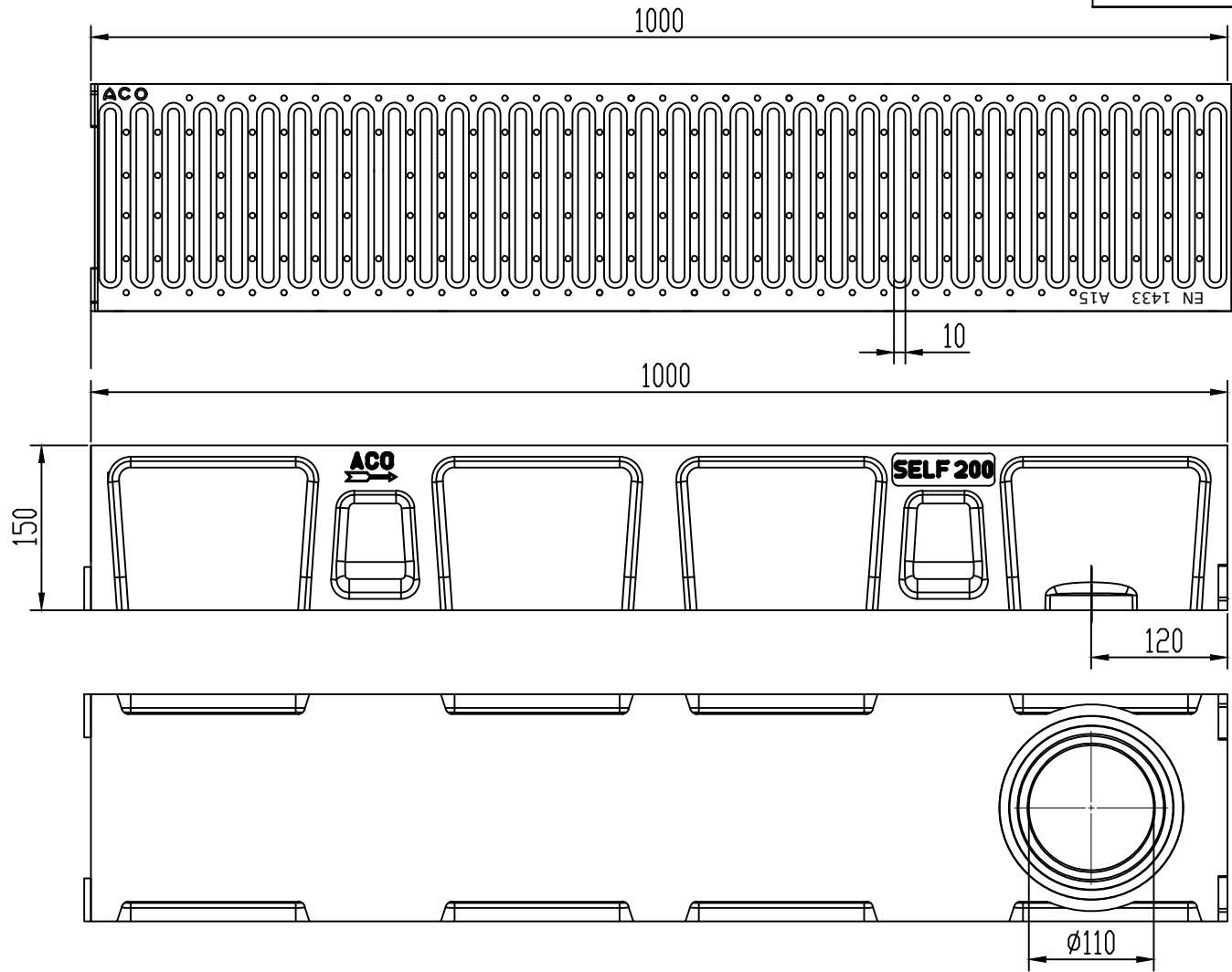
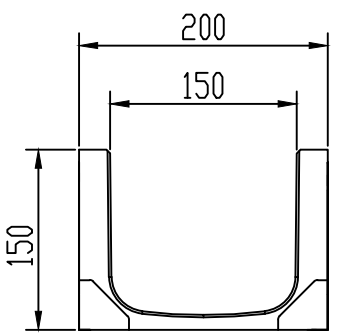
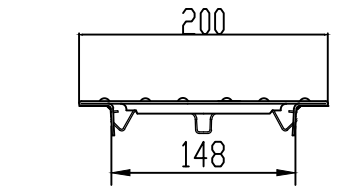

GRELHA PASSARELA AÇO GALVANIZADO - A 15

FUMINAS

www.fuminas.com.br

ESC. 1:5

Description:

PRODUTO CODIGO 00224

Canal de Concreto Polímero - CI A 15
Sistema de encaixe macho e fêmea.

	Date	Name
Dwg.		
Comp.		
Norm		
Reference Number:		
COD. 00224		
ACO SELF		
Self200 H15 - A15		
Measures: mm		

FUMINAS

FUPLASTIC