

Comprimento = 100cm		Largura = 20,0cm	
Classe de carga	Altura (cm)	Peso (kg)	Código
B125	15,0	23,8	00223

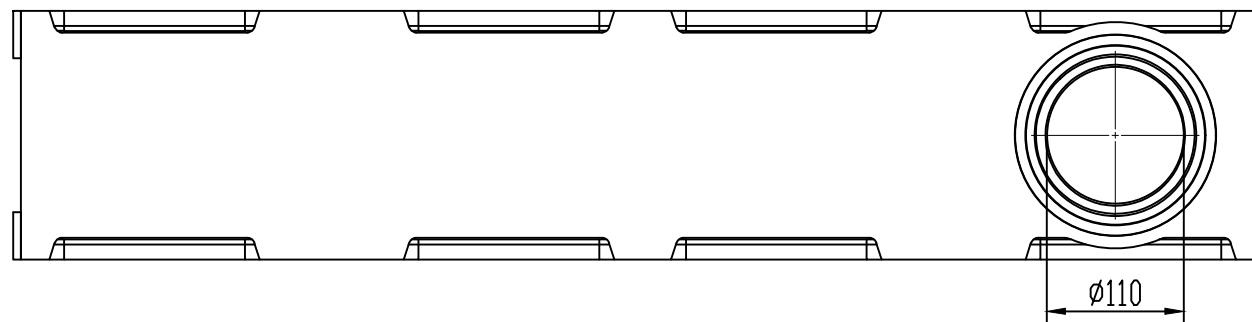
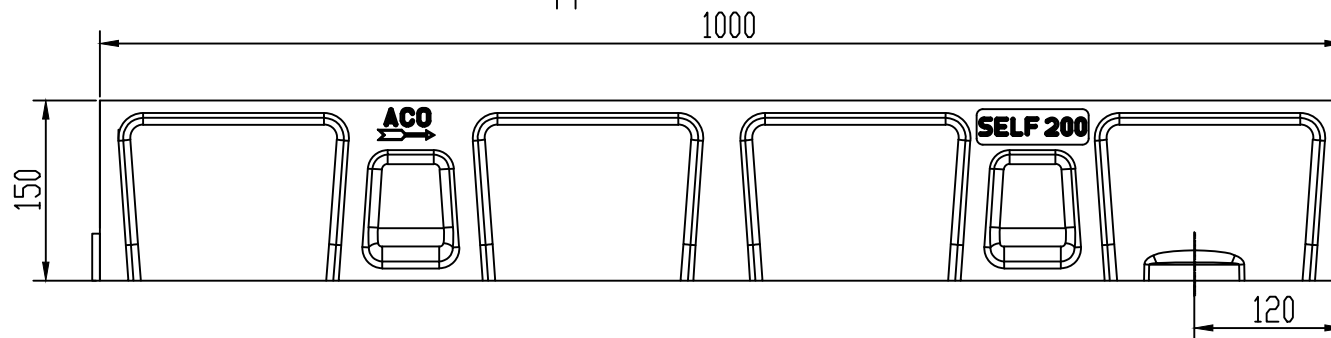
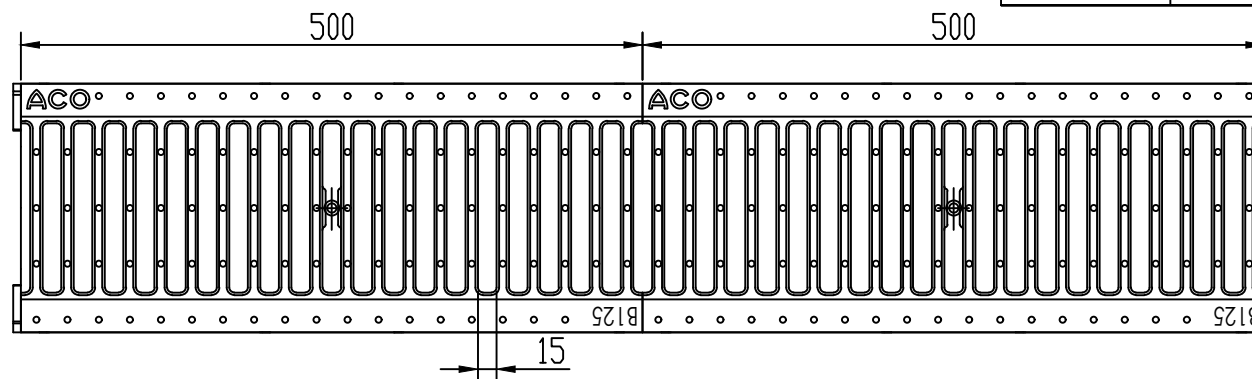
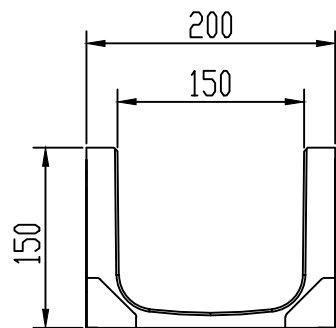
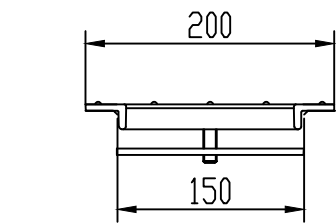

GRELHA PASSARELA AÇO GALVANIZADO - B125

Description:

PRODUTO CODIGO 00223

Canal de Concreto Polímero - CI B 125
Sistema de encaixe macho e fêmea.

	Date	Name
Dwg.		
Comp.		
Norm		
Reference Number:		
COD. 00223		
ACO SELF		
Self200 H15 - B125		
Measures: mm		

FUMINAS
FUPLASTIC

FUMINAS